



INSTALLATION INSTRUCTIONS FOR PART 99-8151

APPLICATIONS Lexus IS 300 2001-2005

99-8151

KIT FEATURES

- DIN Radio Provision With Pocket
- ISO Radio Provision With Pocket
- Two ISO Units Provision
- Double DIN Radio Provision

KIT COMPONENTS

- (A) Radio Housing • (B) Pocket Trim Plate
(C) Double DIN Trim Plate • (D) ISO Trim Plate
(E) Pocket • (F) Rear Support Bracket
(G) Mounting Brackets • (H) Double DIN Spacer Brackets • (I) ISO Snap-in Brackets
(J) (6) #8X3/8" Phillips Truss Head Screws • (K) (2) #8X3/8" Phillips Pan Head Screws

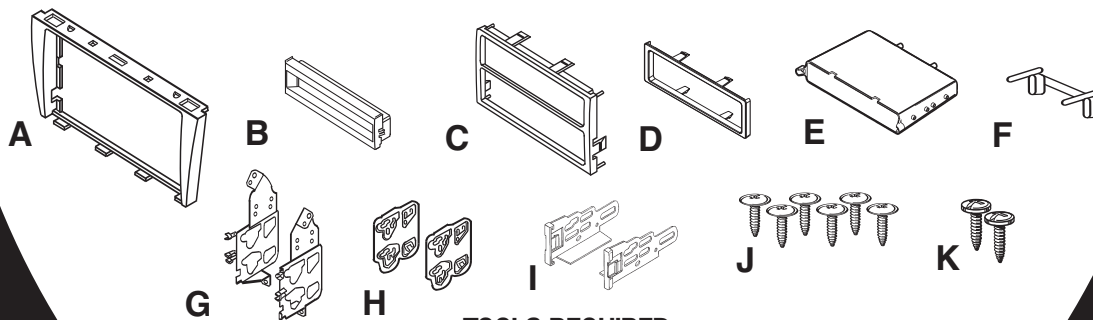

TOOLS REQUIRED:

Phillips Screwdriver • Small Flat Blade Screwdriver or Panel Removal Tool • Cutting Tool

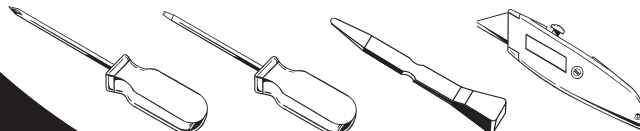

1-800-221-0932



www.metraonline.com

© COPYRIGHT 2004 METRA ELECTRONICS CORPORATION



TABLE OF CONTENTS

Dash Disassembly

Lexus IS 300 2001-2005 1, 2

Kit Assembly

DIN Radio Provision with Pocket 3, 4

ISO Radio Provision with Pocket 5, 6

Double DIN Radio Provision 7, 8

Two ISO Units Provision 9, 10

Final Assembly 11

LEXUS IS 300 2001-2005

1 ***NOTE: Disconnect the negative battery terminal to prevent an accidental short circuit.***

2 Using a small flat blade screwdriver, unsnap and remove the liner from the tray above the center vents. (Figure A)

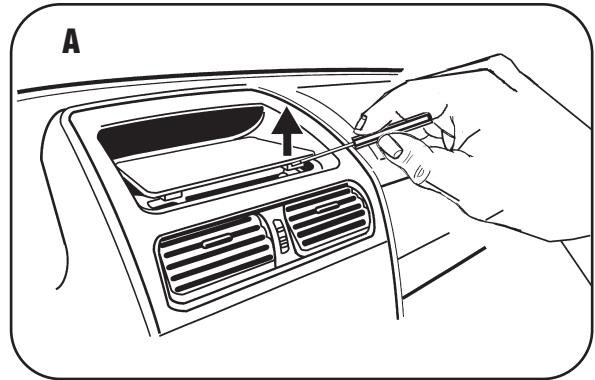

3 Remove (2) Phillips screws from inside the tray. (Figure B)

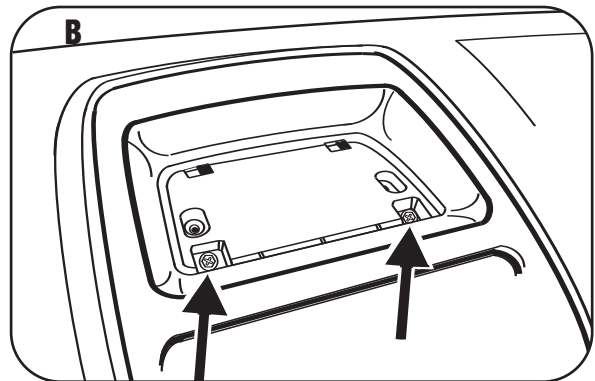

4 Using a small flat blade screw driver, unsnap and remove the center trim panel including vents and tray. (Figure C)

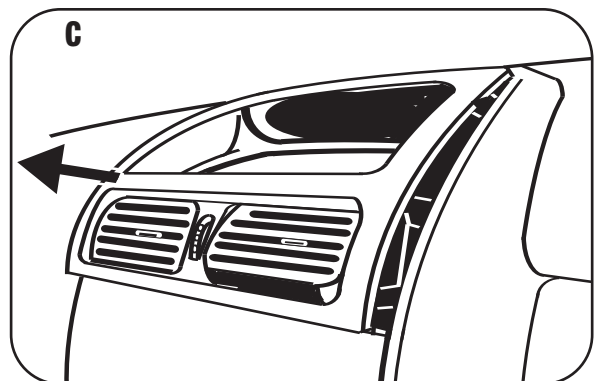

LEXUS IS 300 2001-2005

- 5** Using a small flat blade screwdriver, unsnap and remove switch panel below radio. (Figure D)
- 6** Remove (4) 10mm bolts securing radio/climate control assembly, unplug and remove assembly. (Figure E)
- 7** Remove (4) Phillips screws securing climate controls to the factory brackets and remove the climate controls.

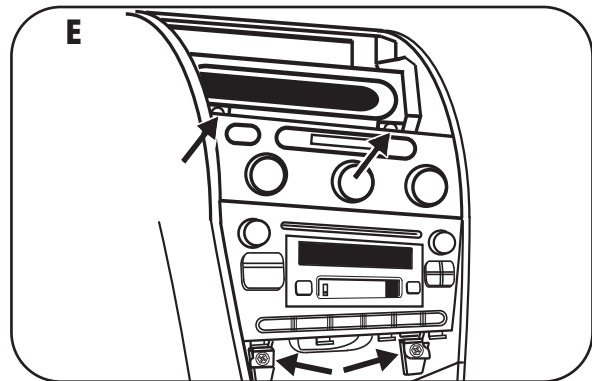
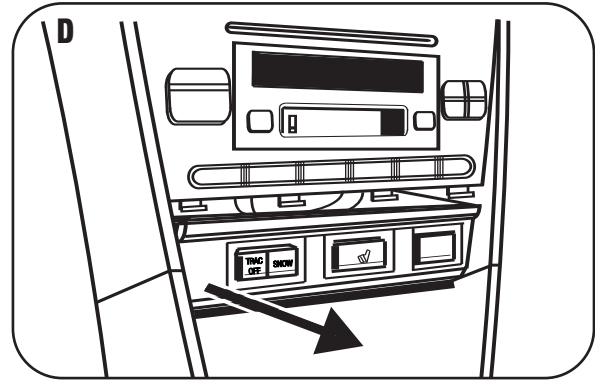

LEXUS IS 300 2001-2005**DIN RADIO PROVISION WITH POCKET**

- 1** Position the pocket trim-plate in the bottom of the radio housing. (Figure A)
- 2** Attach the pocket to the pocket trim-plate using (2) #8 x 3/8" Phillips truss head screws provided with the kit. (Figure B)
- 3** Secure the mounting brackets to radio housing/pocket assembly using (2) #8 x 3/8" Phillips truss head screws and (2) #8 x 3/8" Phillips pan head screws provided with the kit. (Figure C)

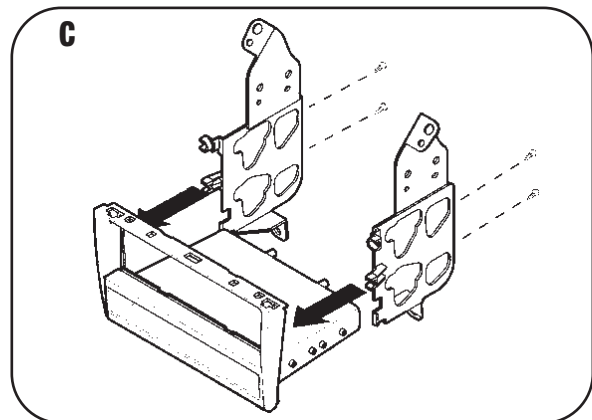
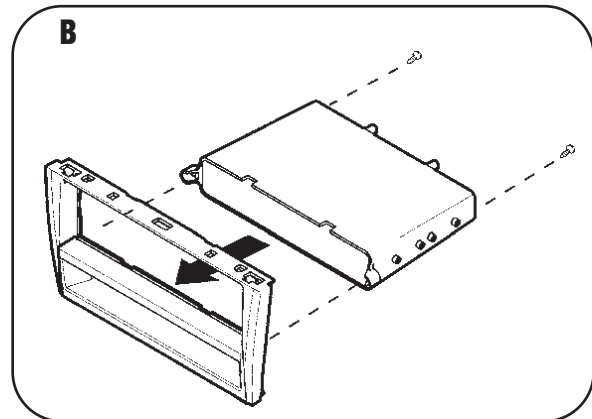
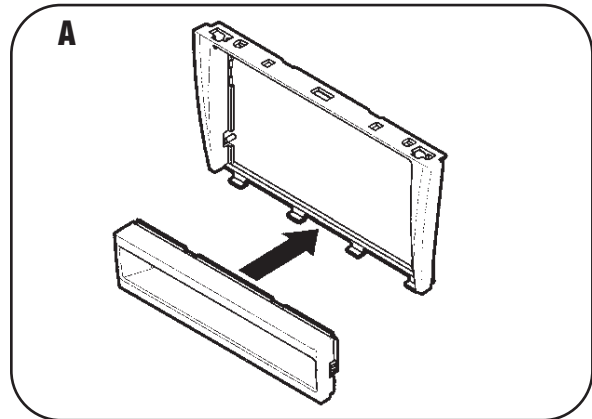

LEXUS IS 300 2001-2005

DIN RADIO PROVISION WITH POCKET

- 4** Mount the rear support bracket to the back of the pocket using (2) #8 x 3/8" Phillips truss head screws provided with the kit. (Figure D)
- 5** Align and engage the (3) tabs on the bottom of the climate controls to the top edge of the radio housing/pocket assembly. Secure the climate controls to the assembly using the (4) factory Phillips screws previously removed from the climate controls.
- 6** Slide the DIN cage into the radio housing/pocket assembly and secure by bending locking tabs outward. (Figure E)
- 7** Slide the DIN radio into the DIN cage until it snaps into place. (Figure F)
- 8** Continue to final assembly.

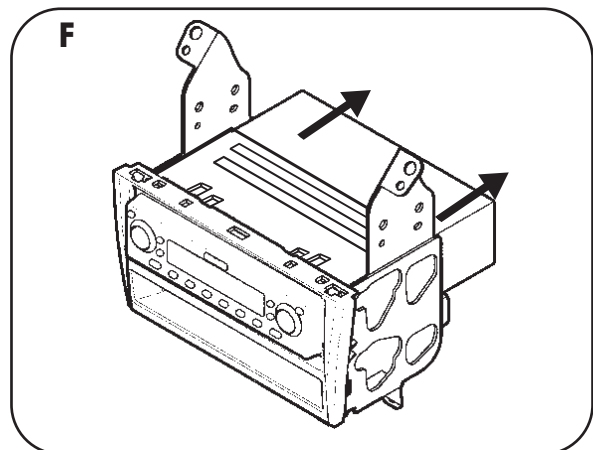
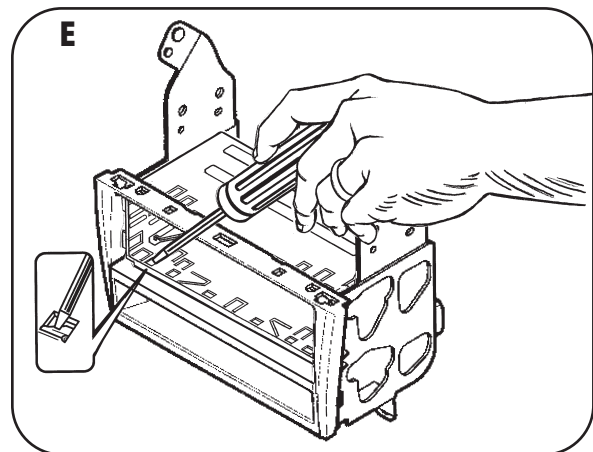
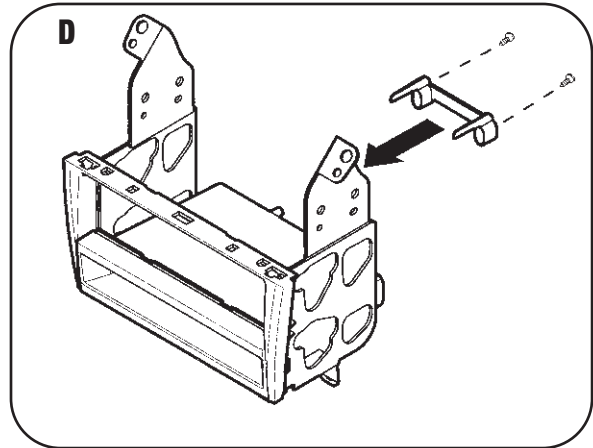

LEXUS IS 300 2001-2005

ISO RADIO PROVISION WITH POCKET

- 1** Position the pocket trim-plate in the bottom of the radio housing. **(Figure A)**
- 2** Attach the pocket to the pocket trim-plate using (2) #8 x 3/8" Phillips truss head screws provided with the kit. **(Figure B)**
- 3** Secure the mounting brackets to radio housing/pocket assembly using (2) #8 x 3/8" Phillips truss head screws and (2) #8 x 3/8" Phillips pan head screws provided with the kit. **(Figure C)**
- 4** Mount the rear support bracket to the back of the pocket using (2) #8 x 3/8" Phillips truss head screws provided with the kit. **(Figure D)**

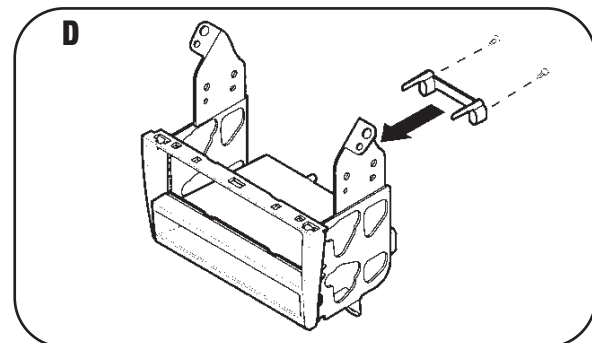
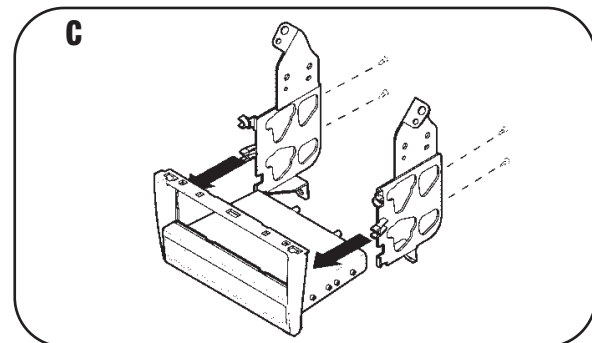
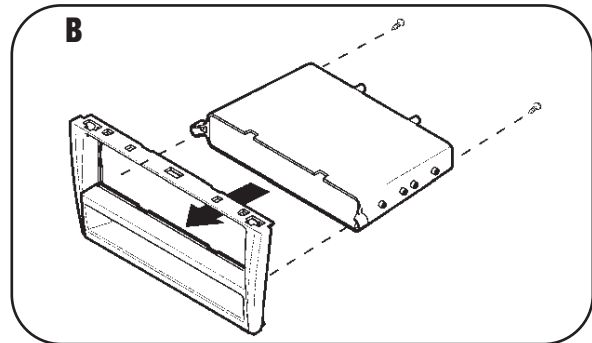
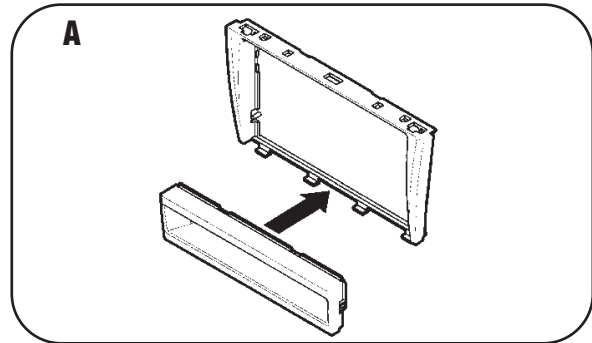

LEXUS IS 300 2001-2005
ISO RADIO PROVISION WITH POCKET

5 Align and engage the (3) tabs on the bottom of the climate controls to the top edge of the radio housing/pocket assembly. Secure the climate controls to the assembly using the (4) factory Phillips screws previously removed from the climate controls.

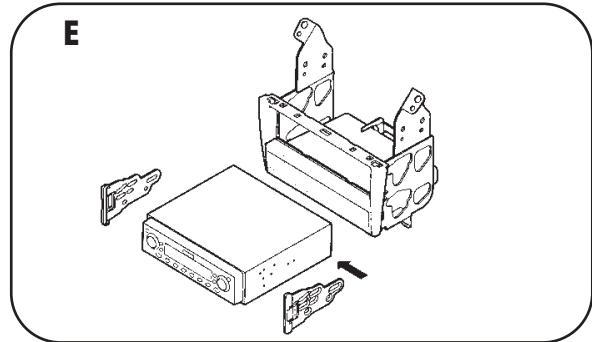

6 Mount the ISO Brackets to the radio with the screws supplied with the radio. (Figure E)

7 Slide the radio into the radio housing assembly until it snaps into place. (Figure F)

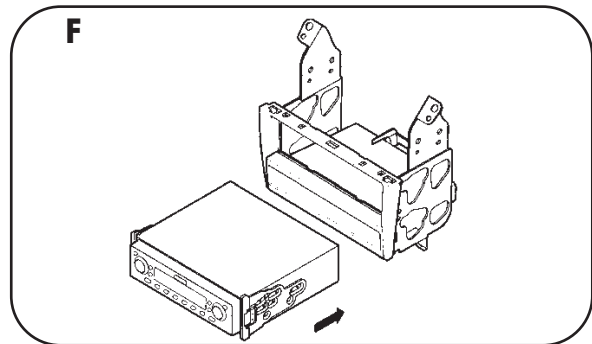

8 Snap the ISO Trim-plate onto the Radio Housing. (Figure G)

9 Continue with final assembly.

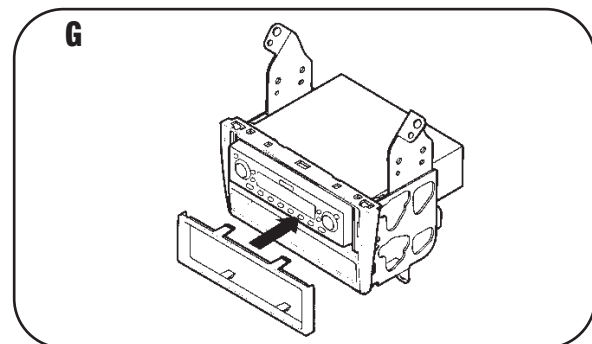

Note: To remove the radio from the housing unclip and remove the ISO trim-plate. Using a small blade screw driver release the clips on the ISO snap in brackets and slide the radio out of the housing assembly.

DOUBLE DIN RADIO PROVISION

- 1** Insert the double din spacer brackets into the mounting brackets.
(Figure A)
- 2** Secure the mounting brackets/spacers to radio housing using (2) #8 x 3/8" Phillips truss head screws and (2) #8 x 3/8" Phillips pan head screws provided with the kit.
(Figure B)
- 3** Align the holes in the brackets/spacers with the holes in the aftermarket double DIN radio and mount the brackets/spacers to the radio using the screws supplied with the radio.
(Figure C)

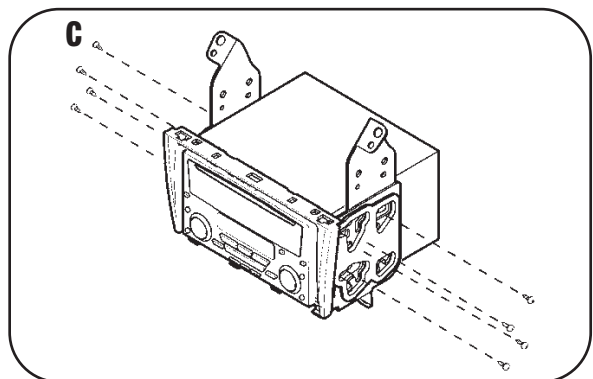
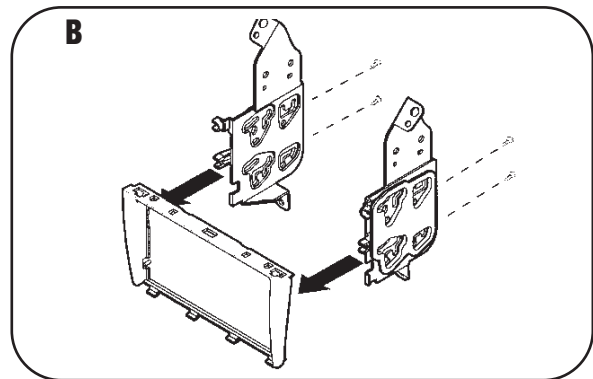
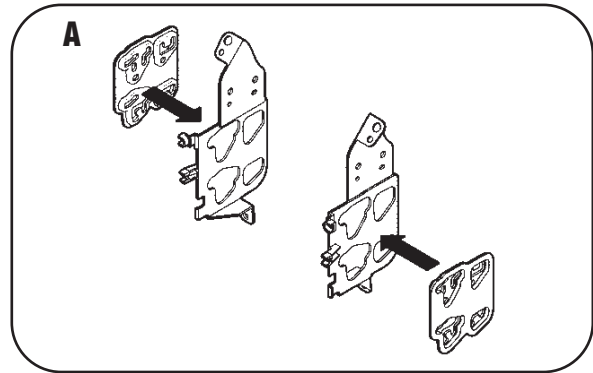

DOUBLE DIN RADIO PROVISION

- 4 Align and engage the (3) tabs on the bottom of the climate controls to the top edge of the radio housing assembly. Secure the climate controls to the assembly using the (4) factory Phillips screws previously removed from the climate controls.
- 5 Cut and remove the center divider from the double DIN trim-plate. (Figure D)
- 6 Snap the double DIN trim-plate onto the radio housing. (Figure E)
- 7 Continue with final assembly.

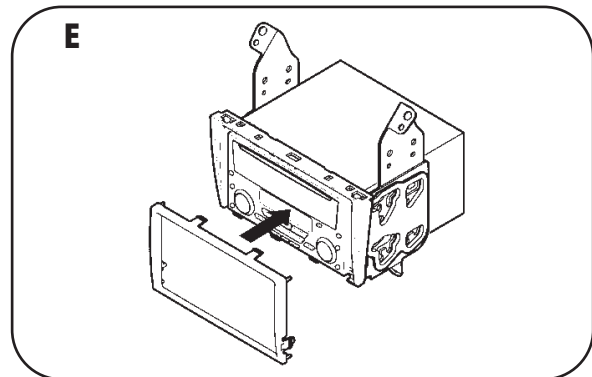
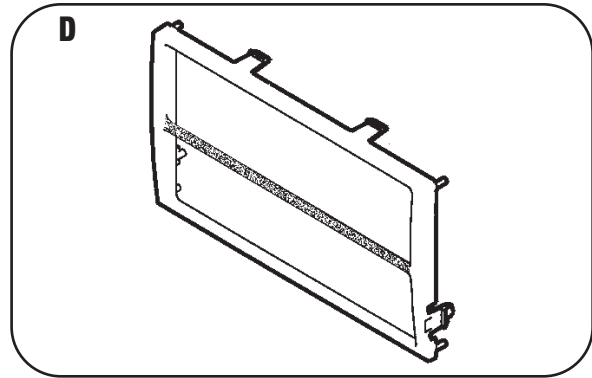

TWO ISO UNITS PROVISION

- 1** Insert the double din spacer brackets into the mounting brackets. (Figure A)
- 2** Secure the mounting brackets/spacers to radio housing using (2) #8 x 3/8" Phillips truss head screws and (2) #8 x 3/8" Phillips pan head screws provided with the kit. (Figure B)
- 3** Align the holes in the brackets/spacers with the holes in each aftermarket ISO unit and mount the brackets/spacers to the aftermarket units using the screws supplied with the units. (Figure C)

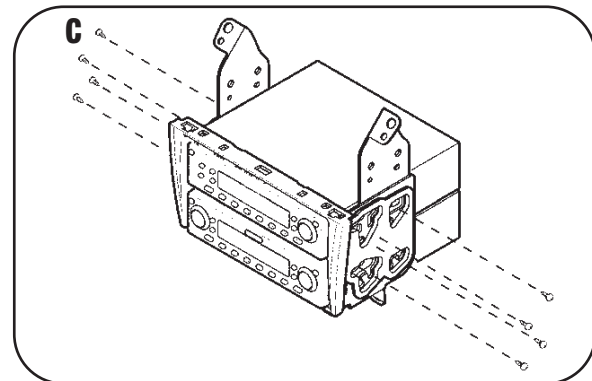
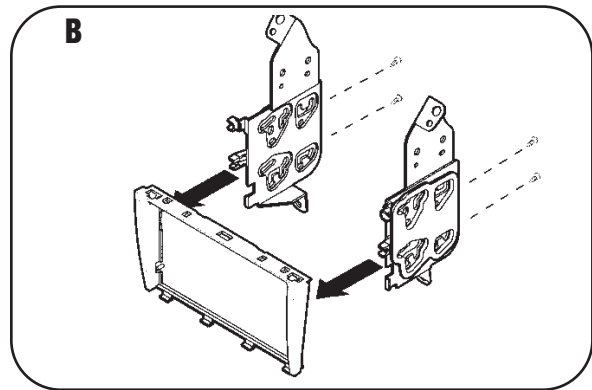
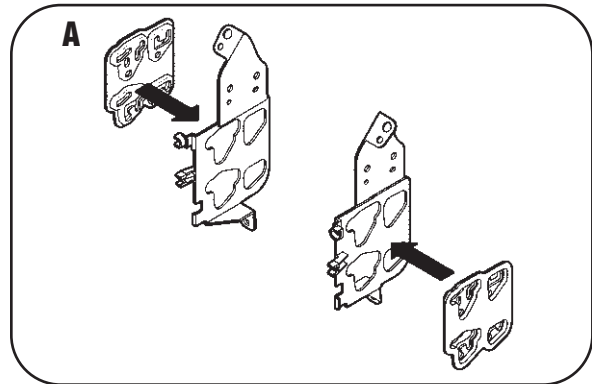

TWO ISO UNITS PROVISION

- 4 Align and engage the (3) tabs on the bottom of the climate controls to the top edge of the radio housing assembly. Secure the climate controls to the assembly using the (4) factory Phillips screws previously removed from the climate controls.
- 5 Snap the double DIN trim-plate onto the radio housing. (Figure D)
- 6 Continue with final assembly.

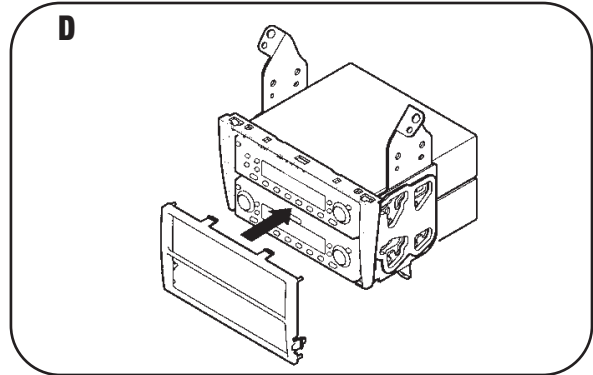

FINAL ASSEMBLY

- 1** Locate the factory wiring harness in the dash and make the connection as shown. Metra recommends using the proper mating adapter and making the connections as shown. (Isolate and individually tape off the ends of any unused wires to prevent electrical short circuit.)
- 2** Re-connect the negative battery terminal and test the unit for proper operation.
- 3** Reassemble radio and dash assemblies in reverse order of disassembly.

FINAL WIRING CONNECTIONS

Make wiring connections using the EIA color code chart shown below and the instructions included with the head unit. Metra recommends making connections as shown below; Strip, Splice, Solder, Tape. Isolate and individually tape off ends of any unused wires to prevent electrical short circuit.

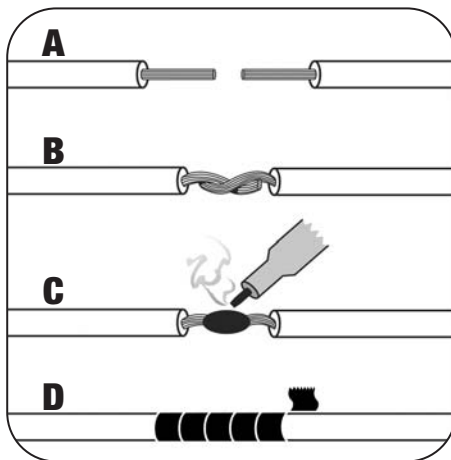

- A) Strip wire ends back 1/2"**
- B) Twist ends together**
- C) Solder**
- D) Tape**

METRA / EIA WIRING CODE

12V Ignition / Acc . . . Red	Right Front (+) Gray
12V Batt / Memory . . Yellow	Right Front (-) Gray / Black
Ground Black*	Left Front (+) White
Power Antenna Blue	Left Front (-) White / Black
Amp Turn-On Blue / White	Right Rear (+) Violet
Amp Ground Black / White	Right Rear (-) Violet / Black
Illumination Orange	Left Rear (+) Green
Dimmer Orange / White	Left Rear (-) Green / Black

***NOTE:** When a Black wire is not present, ground radio to vehicle chassis.
All colors may not be present on all leads due to manufacturer's specifications.

99-8151 INSTRUCTIONS



1-800-221-0932



www.metraonline.com

REV. 04/06/06

© COPYRIGHT 2004 METRA ELECTRONICS CORPORATION

INST99-8151